

TRIAD

M A G N E T I C S

POWER TRANSFORMERS

CHASSIS MOUNT - WORLD SERIES

80033 Rev. E

DESCRIPTION : TRIAD chassis mount World Series transformers are designed to meet U.S. and international standards including CSA, IEC, VDE and UL requirements. The transformers consist of a dual bobbin design positioned inside an insulating shroud, and constructed with UL approved high temperature material. This design eliminates the need for electrostatic shielding since there is minimal capacitance between coils when using a dual bobbin configuration. The primary and secondary are both electrically isolated from each other, and from the core itself. Chassis mount World Series transformers are available in sizes ranging from 25 VA to 175 VA, and are equipped with convenient "quick connect" terminals.

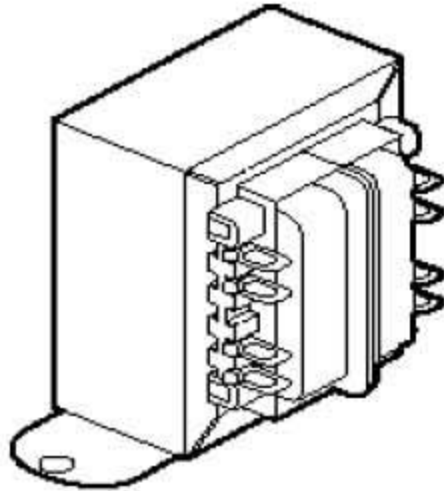

FIGURE A



UL:
FILE E53148, UL 506, GENERAL PURPOSE.

CSA:
FILE LR 37220, C22.2 NO. 66,
GENERAL PURPOSE.

VDE:
FILE 18786-3390-9001, VDE/EN 60 950,
(IEC 950) INFORMATION TECHNOLOGY
EQUIPMENT

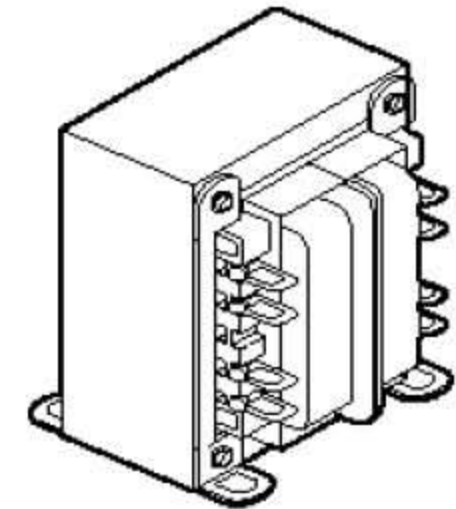

FIGURE B

WORLD SERIES		CT = CENTER TAP		MOUNTING HOLE SIZES: 25 VA, 43 VA = 3/16"; 80 VA, 130 VA, 175 VA = 13/64 X 3/8"												WT
TYPE NO.	FIG.	VA	SECONDARY		DIMENSIONS								Mounting		Lbs.	
			SERIES	PARALLEL	H	W	D	A	B	C	T	MW	ML			
VPS10-2500	A	25	10.0V CT @ 2.5A	5.0V @ 5.0A	2 5/16	2 13/16	1 15/16	2	1 1/8	5/16	3/16	2 3/8	-	1.25		
VPS10-4300	A	43	10.0V CT @ 4.3A	5.0V @ 8.6A	2 11/16	3 1/8	2	2 5/16	1 1/8	5/16	3/16	2 13/16	-	1.6		
VPS10-8000	B	80	10.0V CT @ 8.0A	5.0V @ 16.0A	3	2 1/2	2 5/16	-	1 3/8	5/16	3/16	2	2 1/4	2.8		
VPS10-13000	B	130	10.0V CT @ 13.0A	5.0V @ 26.0A	3 3/8	2 13/16	2 11/16	-	1 5/8	3/8	1/4	2 1/4	2 1/2	4.1		
VPS10-17500	B	175	10.0V CT @ 17.5A	5.0V @ 35.0A	3 3/4	3 1/8	2 13/16	-	1 5/8	3/8	1/4	2 1/2	2 1/2	5.5		
VPS12-2000	A	25	12.6V CT @ 2.0A	6.3V @ 4.0A	2 5/16	2 13/16	1 15/16	2	1 1/8	5/16	3/16	2 3/8	-	1.25		
VPS12-3400	A	43	12.6V CT @ 3.4A	6.3V @ 6.8A	2 11/16	3 1/8	2	2 5/16	1 1/8	5/16	3/16	2 13/16	-	1.6		
VPS12-6300	B	80	12.6V CT @ 6.3A	6.3V @ 12.6A	3	2 1/2	2 5/16	-	1 3/8	5/16	3/16	2	2 1/4	2.8		
VPS12-10300	B	130	12.6V CT @ 10.3A	6.3V @ 20.6A	3 3/8	2 13/16	2 11/16	-	1 5/8	3/8	1/4	2 1/4	2 1/2	4.1		
VPS12-14000	B	175	12.6V CT @ 14.0A	6.3V @ 28.0A	3 3/4	3 1/8	2 13/16	-	1 5/8	3/8	1/4	2 1/2	2 1/2	5.5		
VPS16-1600	A	25	16.0V CT @ 1.6A	8.0V @ 3.2A	2 5/16	2 13/16	1 15/16	2	1 1/8	5/16	3/16	2 3/8	-	1.25		
VPS16-2700	A	43	16.0V CT @ 2.7A	8.0V @ 5.4A	2 11/16	3 1/8	2	2 5/16	1 1/8	5/16	3/16	2 13/16	-	1.6		
VPS16-5000	B	80	16.0V CT @ 5.0A	8.0V @ 10.0A	3	2 1/2	2 5/16	-	1 3/8	5/16	3/16	2	2 1/4	2.8		
VPS16-8100	B	130	16.0V CT @ 8.1A	8.0V @ 16.2A	3 3/8	2 13/16	2 11/16	-	1 5/8	3/8	1/4	2 1/4	2 1/2	4.1		
VPS16-11000	B	175	16.0V CT @ 11.0A	8.0V @ 22.0A	3 3/4	3 1/8	2 13/16	-	1 5/8	3/8	1/4	2 1/2	2 1/2	5.5		
VPS20-1250	A	25	20.0V CT @ 1.25A	10.0V @ 2.5A	2 5/16	2 13/16	1 15/16	2	1 1/8	5/16	3/16	2 3/8	-	1.25		
VPS20-2200	A	43	20.0V CT @ 2.2A	10.0V @ 4.4A	2 11/16	3 1/8	2	2 5/16	1 1/8	5/16	3/16	2 13/16	-	1.6		
VPS20-4000	B	80	20.0V CT @ 4.0A	10.0V @ 8.0A	3	2 1/2	2 5/16	-	1 3/8	5/16	3/16	2	2 1/4	2.8		
VPS20-6500	B	130	20.0V CT @ 6.5A	10.0V @ 13.0A	3 3/8	2 13/16	2 11/16	-	1 5/8	3/8	1/4	2 1/4	2 1/2	4.1		
VPS20-8800	B	175	20.0V CT @ 8.8A	10.0V @ 17.6A	3 3/4	3 1/8	2 13/16	-	1 5/8	3/8	1/4	2 1/2	2 1/2	5.5		
VPS24-1000	A	25	24.0V CT @ 1.0A	12.0V @ 2.0A	2 5/16	2 13/16	1 15/16	2	1 1/8	5/16	3/16	2 3/8	-	1.25		
VPS24-1800	A	43	24.0V CT @ 1.8A	12.0V @ 3.6A	2 11/16	3 1/8	2	2 5/16	1 1/8	5/16	3/16	2 13/16	-	1.6		
VPS24-3300	B	80	24.0V CT @ 3.3A	12.0V @ 6.6A	3	2 1/2	2 5/16	-	1 3/8	5/16	3/16	2	2 1/4	2.8		
VPS24-5400	B	130	24.0V CT @ 5.4A	12.0V @ 10.8A	3 3/8	2 13/16	2 11/16	-	1 5/8	3/8	1/4	2 1/4	2 1/2	4.1		
VPS24-7300	B	175	24.0V CT @ 7.3A	12.0V @ 14.6A	3 3/4	3 1/8	2 13/16	-	1 5/8	3/8	1/4	2 1/2	2 1/2	5.5		
VPS28-900	A	25	28.0V CT @ 0.9A	14.0V @ 1.8A	2 5/16	2 13/16	1 15/16	2	1 1/8	5/16	3/16	2 3/8	-	1.25		
VPS28-1500	A	43	28.0V CT @ 1.5A	14.0V @ 3.0A	2 11/16	3 1/8	2	2 5/16	1 1/8	5/16	3/16	2 13/16	-	1.6		
VPS28-2800	B	80	28.0V CT @ 2.8A	14.0V @ 5.6A	3	2 1/2	2 5/16	-	1 3/8	5/16	3/16	2	2 1/4	2.8		
VPS28-4600	B	130	28.0V CT @ 4.6A	14.0V @ 9.2A	3 3/8	2 13/16	2 11/16	-	1 5/8	3/8	1/4	2 1/4	2 1/2	4.1		
VPS28-6250	B	175	28.0V CT @ 6.25A	14.0V @ 12.5A	3 3/4	3 1/8	2 13/16	-	1 5/8	3/8	1/4	2 1/2	2 1/2	5.5		
VPS36-700	A	25	36.0V CT @ 0.7A	18.0V @ 1.4A	2 5/16	2 13/16	1 15/16	2	1 1/8	5/16	3/16	2 3/8	-	1.25		
VPS36-1200	A	43	36.0V CT @ 1.2A	18.0V @ 2.4A	2 11/16	3 1/8	2	2 5/16	1 1/8	5/16	3/16	2 13/16	-	1.6		
VPS36-2200	B	80	36.0V CT @ 2.2A	18.0V @ 4.4A	3	2 1/2	2 5/16	-	1 3/8	5/16	3/16	2	2 1/4	2.8		
VPS36-3600	B	130	36.0V CT @ 3.6A	18.0V @ 7.2A	3 3/8	2 13/16	2 11/16	-	1 5/8	3/8	1/4	2 1/4	2 1/2	4.1		
VPS36-4800	B	175	36.0V CT @ 4.8A	18.0V @ 9.6A	3 3/4	3 1/8	2 13/16	-	1 5/8	3/8	1/4	2 1/2	2 1/2	5.5		
VPS56-2300	B	80	56.0 CT @ 2.3A	28.0V @ 4.6A	3 3/8	2 7/8	3 1/16	2 7/8	1 1/2	3/8	1/4	2 1/4	2 1/2	4.2		
VPS230-110	A	25	230.0V CT @ 0.11A	115.0V @ 0.22A	2 5/16	2 13/16	1 15/16	2	1 1/8	5/16	3/16	2 3/8	-	1.25		
VPS230-190	A	43	230.0V CT @ 0.19A	115.0V @ 0.38A	2 11/16	3 1/8	2	2 5/16	1 1/8	5/16	3/16	2 13/16	-	1.6		
VPS230-350	B	80	230.0V CT @ 0.35A	115.0V @ 0.7A	3	2 1/2	2 5/16	-	1 1/8	5/16	3/16	2	2 1/4	2.8		
VPS230-570	B	130	230.0V CT @ 0.57A	115.0V @ 1.14A	3 3/8	2 13/16	2 11/16	-	1 3/8	5/16	1/4	2 1/4	2 1/2	4.1		
VPS230-760	B	175	230.0V CT @ 0.76A	115.0V @ 1.52A	3 3/4	3 1/8	2 13/16	-	1 5/8	3/8	1/4	2 1/2	2 1/2	5.5		

TRIAD

MAGNETICS

POWER TRANSFORMERS

CHASSIS MOUNT - WORLD SERIES

80033 rev E

TECHNICAL NOTES:

- 1 HI-POT TESTED AT 4,000 VRMS.
- 2 BOTH PRIMARY AND SECONDARY COILS MAY BE CONNECTED AS EITHER SERIES OR PARALLEL, BUT BOTH MUST BE USED SIMULTANEOUSLY
- 3 "." REFERS TO POLARITY

INPUT	TIE	APPLY TO	SECONDARY (POLARITY)			
			SERIES TIE	SERIES OUTPUT	PARALLEL TIE	PARALLEL OUTPUT
115V	2 TO 6 & 1 TO 5	2 TO 1	11 TO 8	7 TO 12	12 TO 8, & 11 TO 7	8 TO 7
230V	2 TO 5	6 TO 1				

